

### SPIRAL DUCT GRILLE

MINIMUM SIZE: 8" X 3"

MAXIMUM SIZE: 48" X 12"

SINGLE AND DOUBLE (VERTICAL & HORIZONTAL) DEFLECTION

ADJUSTABLE BLADES

EXTRUDED ALUMINUM; 6063-T5

FINISH - SA (SATIN ANODIZE) OR W (WHITE PAINTED)

OPTIONAL AIR SCOOP WITH SCREW ADJUSTMENT

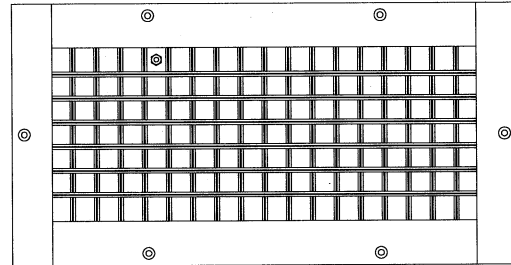

FACE VIEW

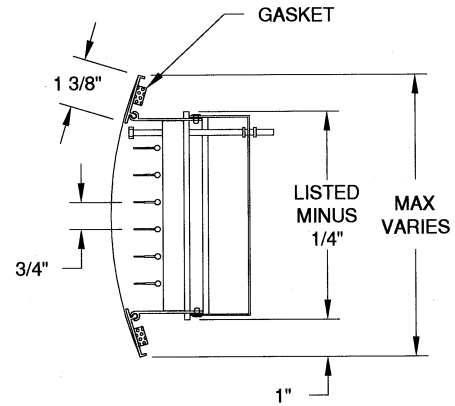
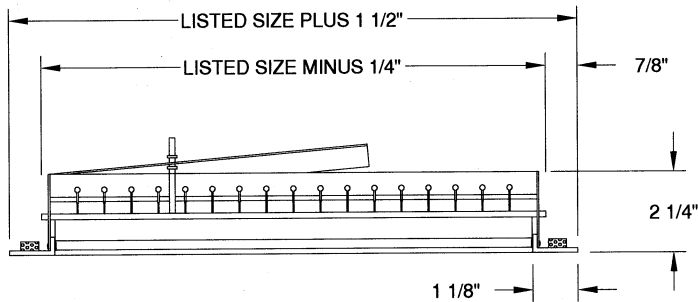

MODEL - S2H - AS

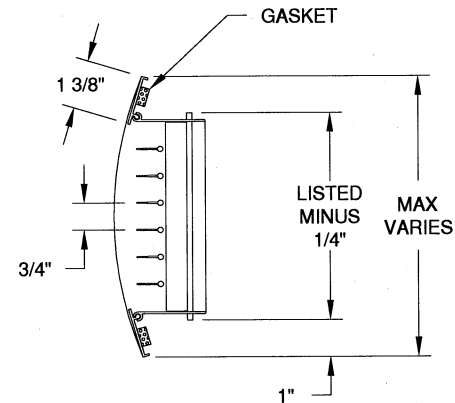
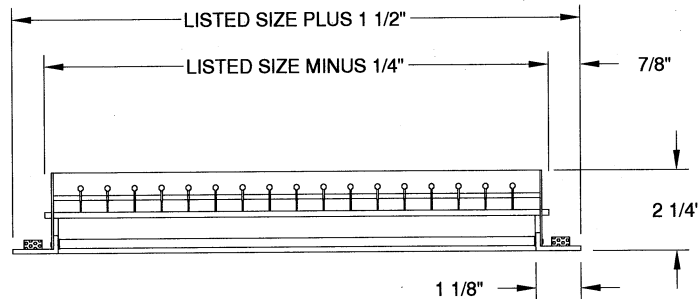

MODEL - S2H

DWG NO.

02HV202C

DATE:

9/8/08

JOB NAME: \_\_\_\_\_

LOCATION: \_\_\_\_\_

ARCHITECT: \_\_\_\_\_

ENGINEER: \_\_\_\_\_

CONTRACTOR: \_\_\_\_\_

FINISH: \_\_\_\_\_